

VPK312

12-Key Network Remote Pad (EU, 2 Gang)



The VPK312 is a 12-key, network-based remote pad designed for use with ATEN Presentation Switches. It offers an intuitive interface for function control of the connected Presentation Switch from a standard 2-gang EU wallmounted keypad. Created with flexibility in mind, the functions and layout of the keys can be easily customized via an intuitive web GUI to meet different application requirements.

Setting up the VPK312 is easy. Simply pair the VPK312 Remote Pad with a Presentation Switch over Ethernet, and the web GUI will assist you through the configuration. With up to 6 Remote Pads can be connected to one Presentation Switch, the VPK312 provides an scalable and affordable control interface to work with Presentation Switches that is perfect for any meeting room, class room, or lecture room.

Features

- 12-key Network Remote Pad for ATEN Presentation Switches
- Easy pairing with a Presentation Switch via the host Presentation Switch's web console
- Effortless configuration via the intuitive web GUI
- Fully customizable for the functions and layout of the keys
- Dual-color button LEDs for clear indication and visibility
- Power redundancy supported when both DC power and Power over Ethernet (PoE) are supplied
- Convenient reset of system and network settings using the built-in reset button
- Firmware upgradable
- Engraved buttons for intuitive port indication and operation

Note: VPK312K1 provides 29 engraved buttons to support multiple function control with [VP2730](#).

Specifications

Interfaces	
Keypad Layout	12 engraved buttons
Ethernet	<ul style="list-style-type: none"> • 1 x RJ-45 Female, 10/100Base-T • Supported Protocol: DHCP, HTTP/ HTTPS • DHCP-enabled. The following default IP settings will be used if no IP is assigned within 30 seconds: IP: 192.168.0.60 Subnet Mask: 255.255.255.0
Reset Button	1 x Semi-recessed Pushbutton
Power Consumption	DC5V:0.8W:3BTU/h POE:1W:4BTU/h Note: <ul style="list-style-type: none"> • The measurement in Watts indicates the typical power consumption of the device with no external loading. • The measurement in BTU/h indicates the power consumption of the device when it is fully loaded.
Connectors	
Power	2-pole terminal block connector
Environmental	
Operating Temperature	0 – 40°C
Storage Temperature	-20 – 60°C
Humidity	0 - 80% RH, Non-Condensing
Physical Properties	
Housing	Plastic
Weight	0.20 kg (0.44 lb)
Dimensions (L x W x H)	8.32 x 14.76 x 4.80 cm (3.28 x 5.81 x 1.89 in.)
Faceplate Dimensions (L x W x H)	8.62 x 15.12 x 0.92 cm (3.39 x 5.95 x 0.36 in.)
Carton Lot	5 pcs
Note	For some of rack mount products, please note that the standard physical dimensions of WxDxH are expressed using a LxWxH format.

Diagram

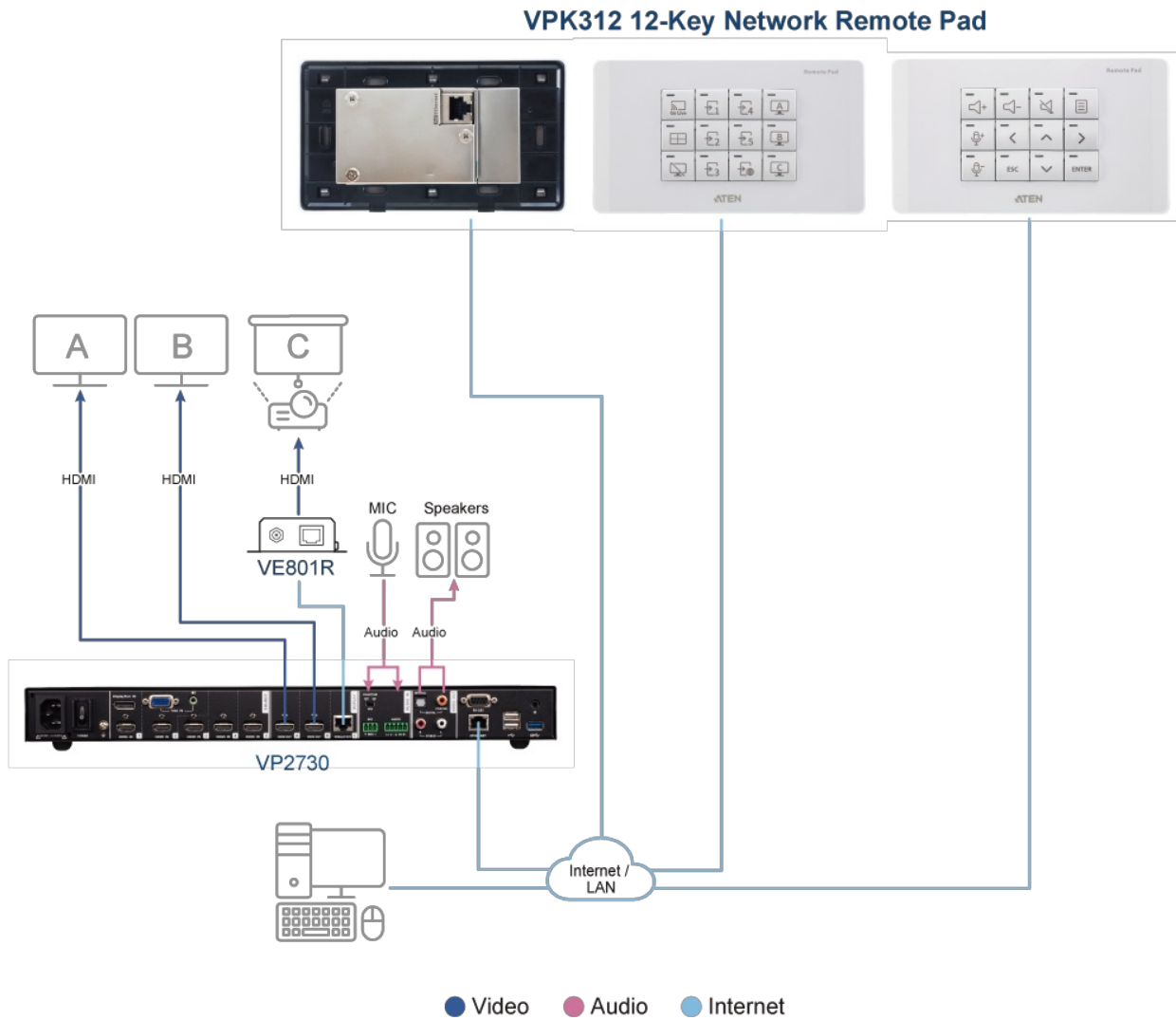

ATEN International Co., Ltd.

3F., No.125, Sec. 2, Datong Rd., Sijhih District., New Taipei City 221, Taiwan
 Phone: 886-2-8692-6789 Fax: 886-2-8692-6767
 www.aten.com E-mail: marketing@aten.com



© Copyright 2015 ATEN® International Co., Ltd.
 ATEN and the ATEN logo are trademarks of ATEN International Co., Ltd.
 All rights reserved. All other trademarks are the property of their respective owners.