

CS1924

4-Port USB 3.0 4K DisplayPort KVMP™ Switch (Cables included)



The ATEN CS1924 4-Port USB 3.0 4K DisplayPort KVMP™ Switch provides the latest innovations in desktop KVM switching technology for the increasing demand of higher video quality and transfer speeds on modern computers. The ATEN CS1924 offers an unprecedented performance of delivering 4K resolution, the next generation USB 3.1 Gen 1 hub with SuperSpeed 5 Gbps data transfer rates and enhanced user-friendly operations.

As a KVM switch, the CS1924 allows users to access four DisplayPort computers from a single USB keyboard, USB mouse and monitor console. Doing so with ease, the CS1924 provides three convenient switching methods – using front panel pushbuttons, mouse, or hotkeys for flexible access to any computer connected to the installation.

The unique independent switching feature allows the KVM control to focus on one computer while the USB peripheral focus is on another computer. This eliminates the need to purchase a separate USB hub or stand-alone peripheral sharer – such as a print server, modem splitter, etc.

With its rich feature set, the CS1924 is designed to surpass all requirements in graphic design, animation, and video-editing applications. Such as CAD/CAM (computer aided design/manufacturing). The CS1924 allows you to share the audio from each of the connected computers. HD audio transmitted by DisplayPort would offer you a different experience.



Features

- 4-port DisplayPort KVMP™ Switch with USB 3.1 Gen1 hub and 2.1 surround sound audio
- One USB console controls 4 computers and 2 USB peripherals
- Computer selection via front panel pushbuttons, hotkeys and mouse ¹
- Independent switching of KVM, USB, and Audio focus
- Superior video quality – 4K UHD (3840 x 2160 @ 60 Hz) and 4K DCI (4096 x 2160 @ 60 Hz)
- 2-port USB 3.1 Gen 1 hub with SuperSpeed 5 Gbps data transfer rates
- DisplayPort 1.2 compliant, HDCP compliant²
- Supports HD audio through DisplayPort³
- Full bass response for high-quality 2.1 channel surround sound systems
- Power On Detection – if a computer is powered off, the CS1924 automatically switches to the next powered-on computer
- Multi-Stream Transport (MST) allows [multiple monitors](#) through a single DisplayPort connector⁴
- DisplayPort Dual-Mode technology (DP++) supports HDMI and DVI signals via a DisplayPort-to-HDMI/DVI DP++ adapter ⁵
- Hot pluggable – add or remove computers without powering down the switch
- Keyboard emulation/bypass feature supports most gaming keyboard
- Mouse emulation/bypass feature supports most mouse drivers and multifunction mice
- Multi-platform support – Windows, Mac and Linux
- Multilingual keyboard mapping supports English, Japanese, French and German keyboards
- Mac keyboard support and emulation⁶
- Auto Scan Mode for monitoring all computers
- Firmware upgradeable

Note:

1. Mouse port switching is only supported under mouse emulation mode with a USB 3-button mouse wheel.

2. For DisplayPort 1.4 compliant display device, make sure to configure the device setting to be compatible with [DisplayPort 1.2](#) to avoid compatibility issue.

3. HD audio through DisplayPort cannot be switched independently.

4. [MST \(Multi-Stream Transport\)](#) requires either monitors that are capable of [DisplayPort 1.2](#) daisy-chaining, or use of a powered DisplayPort [MST](#) Hub. A DisplayPort v1.1a display can be the last display in a DisplayPort v1.2 chain. The PC source must be [DisplayPort 1.2](#) compliant.

5. DisplayPort Dual – Mode technology (DP++) does not require an active adapter for most single display setups. Active DisplayPort adapters are recommended if you are unsure of the video source's DP++ compatibility.

6. PC keyboard combinations emulate Mac keyboards. Mac keyboards only work with their own operating system.

Specifications

Computer Connections	4
Port Selection	Hotkey, Pushbutton, Mouse
Connectors	
Console Ports	2 x USB Type A Female (Black) 1 x DisplayPort Female (Black) 2 x 3.5mm Audio Jack Female (Green; 1 x front, 1 x rear) 2 x 3.5mm Audio Jack Female (Pink; 1 x front, 1 x rear)
KVM (Computer) Ports	4 x USB3.1 Gen1 Type B Female (Blue) 4 x DisplayPort Female (Black) 4 x 3.5mm Audio Jack Female (Green) 4 x 3.5mm Audio Jack Female (Pink)
Power	1 x DC Jack
USB Hub	2 x USB3.1 Gen1 Type A Female (Blue; 1 x front panel; 1 x rear panel)
Switches	
Selected	4 x Pushbutton
LEDs	
On Line /Selected	4 (Orange)
USB Link	4 (Green)
Emulation	
Keyboard / Mouse	USB
Video	Up to 4096 x 2160 @ 60Hz, 2560 x 1440 @ 144Hz
Scan Interval	1-99 Seconds (Default: 5 sec.)
Power Consumption	DC5V:2.99W:57BTU/h Note: ● The measurement in Watts indicates the typical power consumption of the device with no external loading. ● The measurement in BTU/h indicates the power consumption of the device when it is fully loaded.
Environmental	
Operating Temperature	0-50°C
Storage Temperature	-20-60°C
Humidity	0-80% RH, Non-condensing
Physical Properties	
Housing	Metal, Plastic
Weight	0.91 kg (2 lb)
Dimensions (L x W x H)	27.00 x 8.80 x 5.55 cm (10.63 x 3.46 x 2.19 in.)
Note	For some of rack mount products, please note that the standard physical dimensions of WxDxH are expressed using a LxWxH format.

Diagram

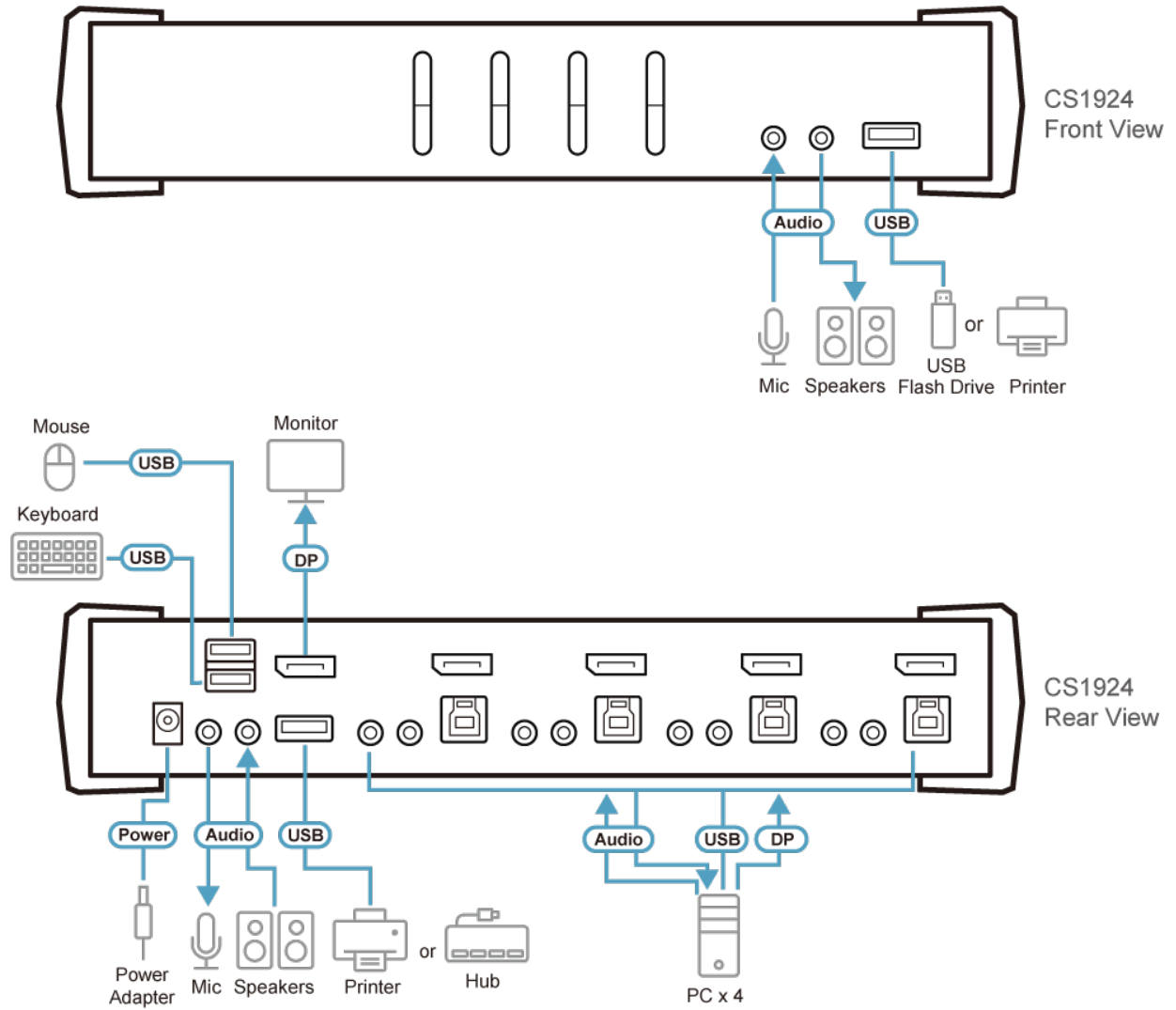

ATEN International Co., Ltd.

3F., No.125, Sec. 2, Datong Rd., Sijhih District., New Taipei City 221, Taiwan
 Phone: 886-2-8692-6789 Fax: 886-2-8692-6767
 www.aten.com E-mail: marketing@aten.com



© Copyright 2015 ATEN® International Co., Ltd.
 ATEN and the ATEN logo are trademarks of ATEN International Co., Ltd.
 All rights reserved. All other trademarks are the property of their respective owners.